



### Model Number

NBB8-F33-E1

### Features

- 8 mm embeddable
- 3-wire DC

### Connection

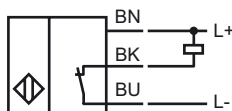

## Dimensions

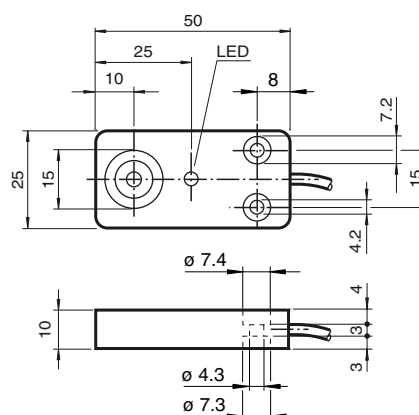

## Technical Data

### General specifications

Switching element function		NPN	NC
Rated operating distance	$s_n$	8 mm	
Installation		embeddable	
Output polarity		DC	
Assured operating distance	$s_a$	0 ... 6.48 mm	
Reduction factor $r_{Al}$		0.3	
Reduction factor $r_{Cu}$		0.2	
Reduction factor $r_{303}$		0.6	

### Nominal ratings

Operating voltage	$U_B$	10 ... 60 V DC
Switching frequency	$f$	0 ... 350 Hz
Hysteresis	$H$	typ. 5 %
Reverse polarity protected		reverse polarity protected
Short-circuit protection		pulsing
Voltage drop	$U_d$	$\leq 3$ V
Operating current	$I_L$	0 ... 200 mA
Off-state current	$I_r$	0 ... 0.1 mA
No-load supply current	$I_0$	$\leq 10$ mA
Indication of the switching state		LED yellow

### Functional safety related parameters

MTTF <sub>d</sub>	1150 a
Mission Time ( $T_M$ )	20 a
Diagnostic Coverage (DC)	0 %

### Ambient conditions

Ambient temperature	-35 ... 70 °C (-31 ... 158 °F)
Storage temperature	-40 ... 85 °C (-40 ... 185 °F)

### Mechanical specifications

Connection type	cable PVC , 2 m
Core cross-section	0.34 mm <sup>2</sup>
Housing material	PBT
Sensing face	PBT
Protection degree	IP67
Note	Tightening torque: 5 Nm

### Compliance with standards and directives

Standard conformity	
Standards	EN 60947-5-2:2007 IEC 60947-5-2:2007

### Approvals and certificates

UL approval	cULus Listed, General Purpose
CSA approval	cCSAus Listed, General Purpose
CCC approval	Certified by China Compulsory Certification (CCC)